

# Float-Boost Charger **POWERHOUSE**<sup>®</sup>

## Function:

**POWER HOUSE** FCBC are designed to supply continuous power to the DC load and simultaneously charge the batteries connected. Input supply form 415 V. AC 3 Phase or 220 V. AC 1 Ph. is converted to regulated DC. The charger has two independent systems.

Normally the DC power is supplied to the load by the Float Charger. It also supplies trickle current to the battery to keep it healthy. If the charging current under Float Mode exceeds a set level, Boost charger is switched ON. It supplies Quick charging current to the battery. On battery reaching the set value, the Boost Charger is switched OFF.

## Application:

Float/ Boost chargers are must in Power Substations, Generating Stations, Telephone Exchanges etc. for control / monitoring systems, tripping circuits and supplying DC power source.

## Specifications:

Aux:	: 415V. AC ( 3 Phase) / 240 V (1 Phase) +/- 20 %/ +/- 10%, 50 Hz. +/- 3 Hz.
Out put	: 30 V, 48 V, 110 V and 220 V. DC supply
Battery Type	: Lead Acid / SMF
Indications and instruments	: Indications for 3 phase mains supply : Float / Boost section : AC Volt meter with selector switch : DC Volt meter with selector switch and battery volt : DC Amps meter for load : DC Amps meter for Charging.
Protection	: MCB for Mains incoming supply : MCB for out put load : Over load cut out by electronics circuit : Over Voltage cut-out by electronics circuit : Single phasing, under voltage for mains
Housing and enclosure:	: Heavy duty Sheet Steel Enclosure Finished with Powder Coated paint.
Mounting	: Floor mounting
Operation	: Auto/Manual
Control	: CC/ CV close loop
Rectifier	: Full wave half controlled bridge
Optional	: Fuse protection for each rectifier element : Fuse failure relay : DC Earth Fault Relay : Alarm Annunciation : Dual Float Charger option : Any other as per requirement.



## BLOCK DIAGRAM

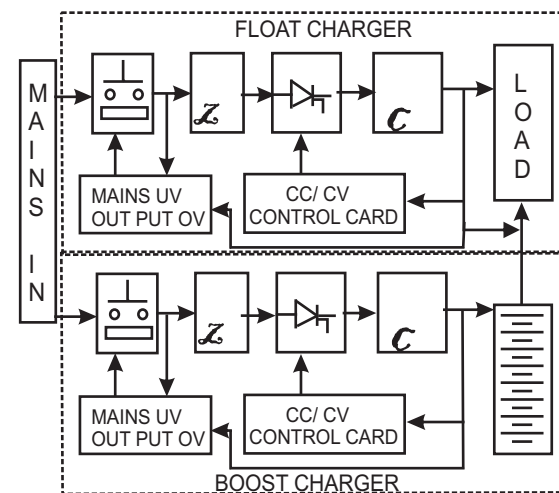

## Ordering Information:

Mains supply Voltage  
Load voltage and current  
Battery type, Voltage and current  
Any optional equipments required



# POWER SERVICES

Innovative Power Solutions

33, Phears Lane, Kolkata -700 073 Ph. +91 (033) 2237-0508

Fax : +91 (033) 25210322 Email: info@indiapowerhouse.net

Visit us at [www.indiapowerhouse.com](http://www.indiapowerhouse.com)